

**ISOMETRIC**

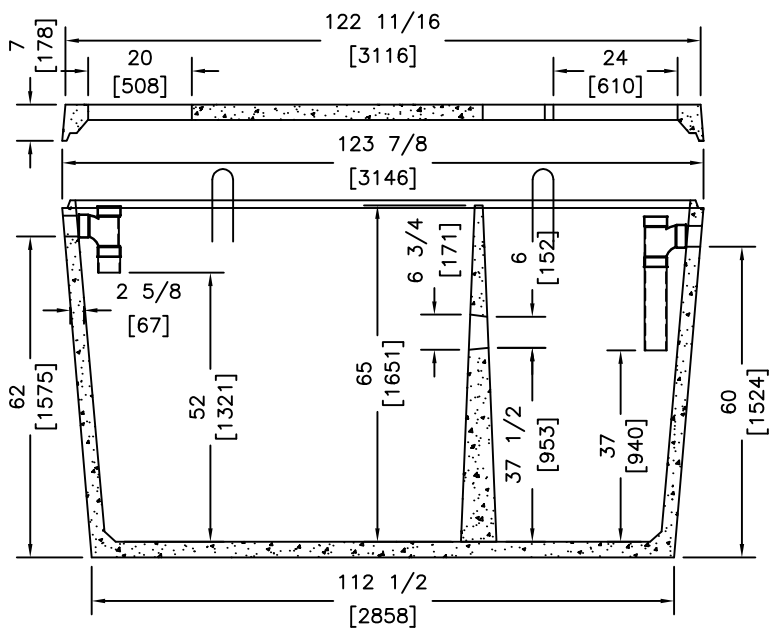
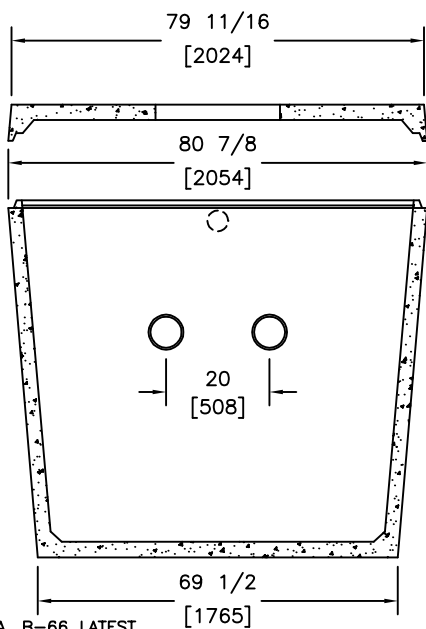

**SECTIONS**

C.S.A. B-66 LATEST  
 32MPa @ 28 DAYS  
 TANK: 4236 kg LID: 1227 kg

REVISED: OCT 1 2019



**KON KAST**  
 products (2005) ltd.

ph: (250) 765 1423  
 fx: (250) 765 0820  
 www.konkast.com

DESCRIPTION

**1500 GAL (6810L)  
 TWO COMPARTMENT  
 SEPTIC TANK**

DRAWN BY: PKR  
 DATE: JUN 20 05  
 SCALE: NTS

DRAWING:

**185**

"Committed To Quality And Service"