

**ASSEMBLY DEPICTING  
3' BURY**

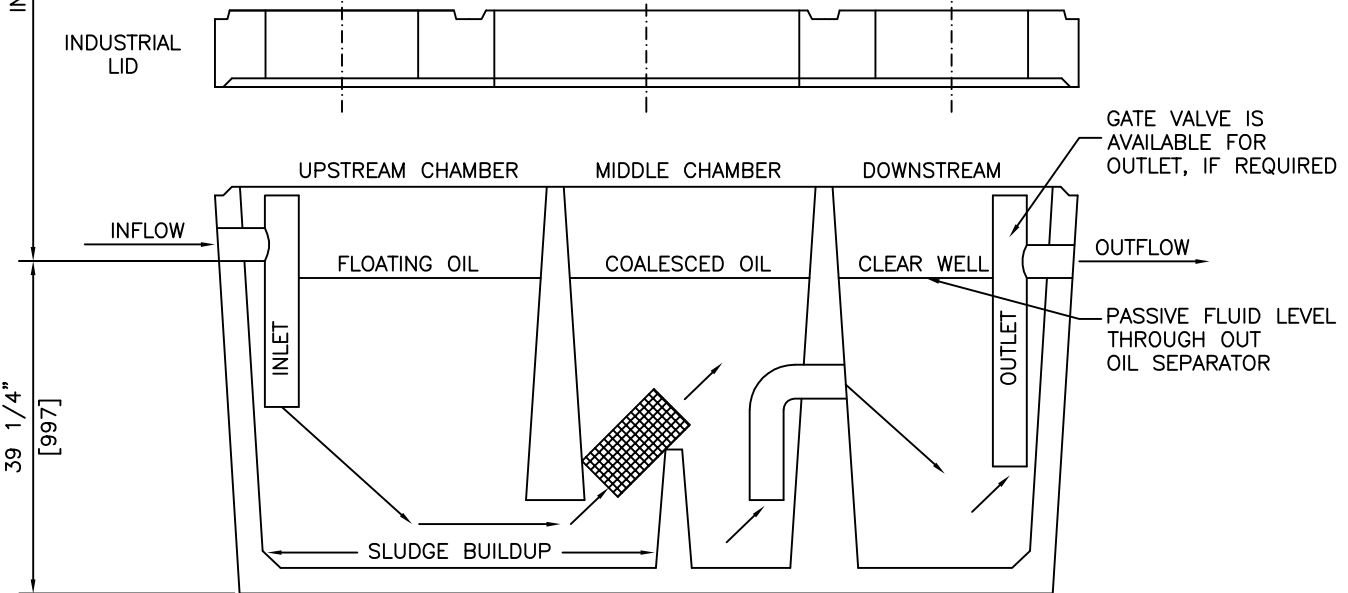
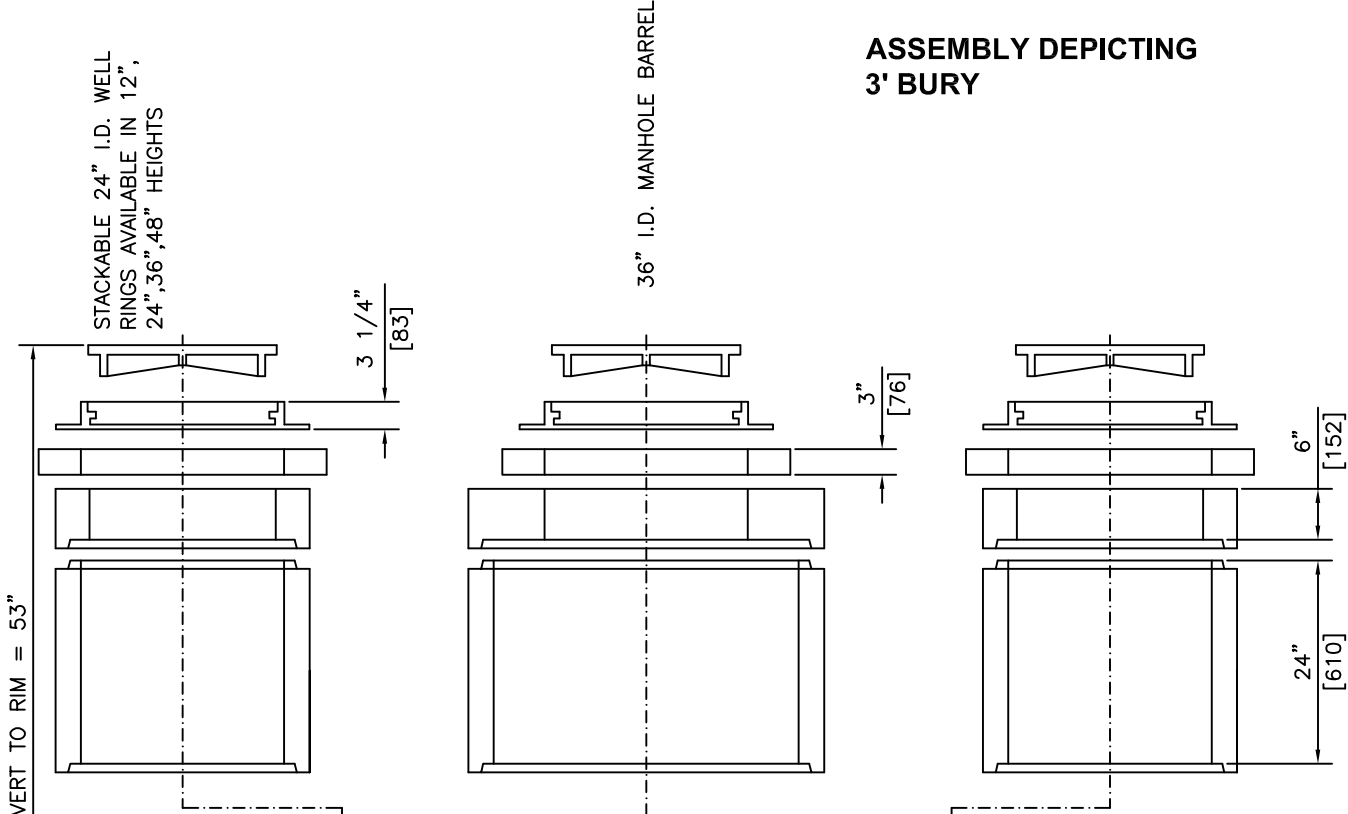

**INSTALLATION SEQUENCE  
AND OPERATION DETAILS**

INDUSTRIAL 600  
GALLON OIL  
INTERCEPTOR TANK

**NOTES:**  
U.S. PATENT No. 6,079,571  
CANADIAN PATENT No. 2,252,307

REVISED: JAN 28 2009

<p><b>A.F.C.</b> AMERICAN FORCETRE OF CANADA Inc.</p>	<p>3891 Irvine Road LAKE COUNTRY, B.C. V4V 2G4</p>	<p>BY: PKR</p>	<p><b>AFC OIL/WATER SEPARATOR : H2O 50GPM</b></p>	<p>ITEM NO.</p>
	<p>PH: (250) 548-0056</p>	<p>DATE: MAR 17 06</p>		
	<p>FX: (250) 765 0820</p>	<p>SCALE: NTS</p>		